

MegaPulse
IMPULSE TESTER
Implantable Test 2

Instruction Manual

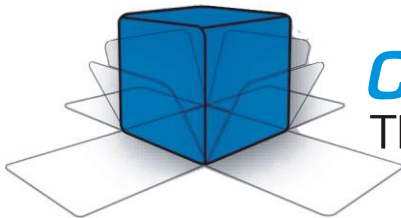

COMPLIANCE WEST USA
The blue box that tests. And tests.

Dear Customer:

Congratulations! Compliance West USA is proud to present you with your MegaPulse Implantable Test 2 Impulse Tester. Your instrument features a groundbreaking logic-controlled circuit design and ergonomic front panel and represents the latest in high voltage impulse testing.

To fully appreciate all the features of your new instrument, we suggest that you take a few moments to review this manual. Compliance West USA stands by your instrument with a full one-year warranty. If the need arises, please don't hesitate to call on us.

Thank you for your trust and confidence.

Table of Contents

An Introduction to Impulse Testing with the MegaPulse tester	2
Safety Precautions	2
Test Personnel	2
Testing Area	2
Safety Techniques	3
Using the MegaPulse Impulse Tester	3
Introduction	5
Operation	7
Setting up your Tester	7
AC Line Voltage Requirements.....	7
Fuse Replacement.....	8
Front and Rear Panel Features.....	8
Testing.....	16
Technical Assistance	17
Maintenance and Calibration	18
Introduction	18
Service Information.....	18
General Maintenance.....	18
Cleaning	18
Calibration Information.....	19

Section 1

An Introduction to Impulse Testing with the MegaPulse tester

The impulse test is designed to simulate impulse surges which occur in everyday life due to nearby lightning strikes, switching transients, and other high-frequency faults on the power distribution network. Impulse testing is the fundamental method for empirical verification of the adequacy of insulation. Other methods of ensuring adequate insulation (AC or DC Dielectric Withstand testing, measurement of over-surface creep age, through-air clearance, or distance-through-insulation) are all extrapolated from the results of impulse testing. The impulse test is performed to ensure that the insulation in question will be able to function properly when subjected to similar impulse surges in the field.

Safety Precautions

The impulse withstand test can generate voltages in excess of 270V peak at potentially lethal current levels. Currents of as little as 5mA at 120 volts can cause death; the MegaPulse can deliver currents of more than 41 Amps peak for very short time duration. The potential for serious injury or death exists and personnel should be aware when they conduct this test.

Test Personnel

Personnel require special training to conduct the impulse test. They should understand electrical fundamentals clearly, and be aware that high voltage is adept and creative at completing a path to ground. Instructions should include a warning against any metal jewelry. Operators should not allow others in the testing area, especially when tests are being conducted. Organization is to be stressed. The operator should keep the area free of unused leads and equipment.

Testing Area

The area used for conducting the impulse test should be as remote as possible from normal production line activities. Only personnel actually conducting the test should be allowed in the area, and it should be taped or roped off to preclude casual entry by other employees. In addition, the area should be marked "WARNING - HIGH VOLTAGE TESTING" or the equivalent to warn others of the nature of the testing taking place.

The bench being used should be non-conductive, and any exposed metal parts should be tied together and grounded. If a conductive surface must be used, it should be grounded. Because of sparking during an impulse test failure, it is not safe to conduct impulse testing in combustible atmospheres.

It is imperative that a good ground be provided to the MegaPulse tester. Before connecting the equipment, ensure that the building wiring provides a low-resistance ground. If the MegaPulse tester is used on a high-resistance grounding circuit, dangerous high voltages may be present to the operator. In addition, the power to the Testing Area should be provided with an easily reached shutoff switch which can be actuated by personnel outside the Area if needed.

Safety Techniques

The high voltage circuit of the MegaPulse Implantable Test 2 can be shut off at any time by turning OFF the rear power switch. Always press TRIGGER to discharge the tester before turning OFF.

The MegaPulse tester is provided with a **VOLTAGE ADJUST** knob on the front panel. This should always be adjusted to the minimum position at the start of testing. In addition, this knob should be adjusted back to the minimum position at the completion of all testing.

The MegaPulse tester is provided with a **CHARGE** switch that is in the unarmed "Standby" setting when the tester is first turned ON. When the yellow **CHARGE** button is lit, the tester will not provide high voltage until the **CHARGE** Button and the **TRIGGER** Button have been pressed in order. To prevent inadvertent operation, the operator should be instructed not to press the **CHARGE** Button until the test is ready.

The MegaPulse tester has been designed for one-touch operation with the right hand. If possible, it should be set up to the left and in front of the equipment under test. The equipment under test should be connected to the MegaPulse tester and then left alone by the operator. After the operator is clear of the Tester and the equipment under test, the operator should turn the rear-panel power switch to ON, press the **CHARGE** Button, adjust the voltage to the desired level (as displayed on the front panel meter), then press the **TRIGGER** Button, with his right hand. This will allow the greatest separation between the operator and the test being conducted. Note that the CHARGE process will stop after 2 minutes if the TRIGGER button is not pressed.

The MegaPulse tester is designed to bleed the high voltage away after the test has concluded. In order to ensure that any voltage present in the equipment being tested has been completely bled away, the operator should not unplug the equipment under test from the MegaPulse until the front panel meter reads a safe level (40 volts or less is generally considered a safe level). Pressing the TRIGGER button before disconnecting main power (or turning the equipment off) will ensure that the internal capacitors are discharged as much as possible.

Using the MegaPulse Impulse Tester

The impulse test involves high voltage and caution should be exercised when using the tester. The **RETURN** lead is referenced to building ground when properly connected. However, both **OUTPUT** and **RETURN** leads must always be treated as Hazardous whenever the power switch of the MegaPulse is in the ON position.

The MegaPulse impulse tester generates the impulse waveform only; it does not determine Passing or Failing results. It is the operator's responsibility to monitor the output waveform and determine Passing or Failing results. In monitoring the impulse waveform, consider the following points: The Impulse waveform is high voltage and high frequency (short duration). Always ensure that the measuring instrument (usually an oscilloscope with a high-voltage probe) is rated for the voltage involved, and that the frequency response of the instrument and probe are capable of measuring the output waveform of the MegaPulse Impulse Tester. A measuring instrument or probe with a low frequency response will result in erroneous readings that could be mis-read.

Pressing the **POLARITY** switch on the front panel can change the polarity of the output waveform. The polarity is Normal when the **NOR** indicator is lit. In this case, the high voltage will appear on the **OUTPUTS** as a positive pulse relative to the **RETURN** jack. When the polarity switch is in the Reverse position (**REV** indicator is lit), the high voltage will appear on the **OUTPUTS** as a negative pulse relative to the **RETURN** jack. The polarity switch only operates when the **CHARGE** LED is lit, i.e. the output is not charged.

Note that the voltage meter may indicate that some residual voltage is present on the main storage capacitor, even when the tester is first turned ON. This is due to inherent charging of the internal capacitors. Pressing the **TRIGGER** switch will discharge the capacitors (be sure not to touch the output and return leads when pressing the trigger switch).

Note that the peak amplitude of the measured output waveform is proportional to the voltage that is read on the front panel of the MegaPulse, but it can be lower, depending on the load.

Determination of Passing and Failing results can prove difficult. To obtain the most accurate results, it is generally necessary to perform multiple impulse tests on a few different test samples (that have adequate insulation to pass the impulse test). Take note of the impulse waveshape, amplitude, and duration. Also note how much variance there is in the waveshape from test to test. Also (if possible), perform impulse testing on some test samples that are known to have inadequate (or damaged) insulation. Take note of the impulse waveshape, amplitude, and duration, when an insulation breakdown occurs.

Section 2

Introduction

This manual contains complete operating, maintenance and calibration information for the Compliance West USA MegaPulse Implantable Test 2 Impulse Tester.

- In case of trouble, the test can be immediately terminated at any time by turning the rear-panel power switch to the OFF position.
- Before the test can commence, the unit must be armed by pressing the **CHARGE** Button. The test will not begin until the **TRIGGER** Button is pushed.
- Operator instructions are printed on the rear panel for quick reference.
- Voltage is discharged by a resistor bank within the MegaPulse tester upon test completion. Discharge progress is shown on the front panel meter.

Your tester is warranted for a period of one year upon shipment of the instrument to the original purchaser.

Waveform specifications and tolerances

Specifications and tolerances for the MegaPulse Implantable Test 2 are the following:

Peak Output Voltage:	140V/270 V +5%, -0% (see Figure 1 and Figure 2 for waveshapes)
Voltage Rise Time:	$1\mu\text{s} < t_r < 5\mu\text{s}$
Open Circuit Duration Time:	$9.5\text{ms} < T_d < 10.5\text{ms}$
Voltage Fall Time:	$1\mu\text{s} < t_f < 5\mu\text{s}$
Commutation Time:	$\leq 2\text{ms}$
Voltage Meter Accuracy:	$\pm 1\%$ tolerance
Duty Cycle:	One pulse every 20 seconds
Ambient Temperature:	15°C – 28°C
Line Voltage regulation:	1%
Repeatability:	The tester is designed to maintain the waveform tolerances during the entire test sequence while testing under specified conditions

All the tolerances are in compliance with the following standards:

- ISO 14117:2012
- ISO 14708-1:2003
- EN 45502-1:2015
- EN 45502-2-2:2008

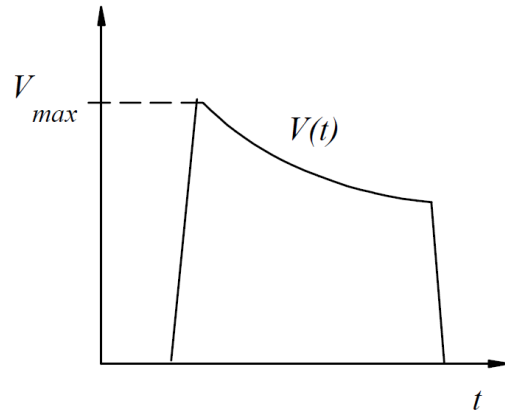

Figure 1. Monophasic waveform.

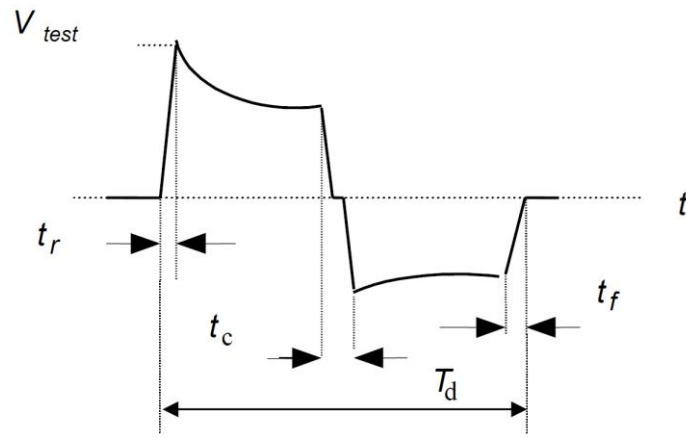

Figure 2. Biphasic waveform.

Section 3

Operation

This section describes how to set up and make measurements with your Tester. We recommend that you read the entire section carefully so that you can use all of the features of your Tester.

Setting up your Tester

Your Tester is shipped in a special protective container that should prevent damage to the instrument during shipping. Check the shipping order against the contents of the container and report any damage or short shipment to Compliance West USA. The container should include the following:

- The MegaPulse Implantable Test 2 Tester.
- 14 High Voltage Test Leads, 1 Black-Black Lead, 1 Red-Red Lead, 1 Green-Red Lead, 1 Blue-Red Lead, 1 White-Red Lead, 1 Yellow-Red Lead, 1 Purple-Red Lead, 1 Red-Green Lead, 1 Green-Green Lead, 1 Blue-Green Lead, 1 White-Green Lead, 1 Yellow-Green Lead, 1 Purple-Green Lead, 1 White-White Lead.
- 1 Power Cord (18AWG)
- This Instruction Manual.

If reshipment of the instrument is necessary, please use the original shipping container. If the original shipping container is not available, be sure that adequate protection is provided to prevent damage during shipment. We recommend that the instrument be surrounded by at least three inches of shock-absorbing material on all sides of the container.

Remove the tester from its container and place it on a test bench.

AC Line Voltage Requirements

AC line voltage requirements for your Tester are noted on the rear panel of the instrument. Do not connect the instrument to a different voltage source. The cord packaged with your MegaPulse Tester is for use in the United States. If another power cord must be used, the cord must be rated for the maximum current noted on the rear panel. It must also meet the requirements of IEC 227 or IEC 245, and mains cords that are certified or approved by any recognized national test house are regarded as meeting this requirement.

Fuse Replacement

There is a user-replaceable fuse (F1) located on the rear panel of the instrument. It is located behind a door in the Power Inlet-Power Switch-Fuse Holder device. The fuse rating is noted on the rear panel. Do not attempt to replace it with a fuse of any other rating.

Use the following procedure to replace the fuse F1:

1. Turn the power switch to the OFF position.
2. Unplug the instrument from the source of supply.
3. Remove the power inlet cord from the instrument.
4. Using a small screwdriver, pry open the fuse holder door.
5. Replace the fuse with a new one of the correct rating.
6. Replace the fuse holder door and power inlet cord.

Front and Rear Panel Features

Before using your Tester, take a few minutes to become familiar with the use of its controls, indicators and connectors. The front panel features of the MegaPulse are shown in **Figure 3** and described in **Table 1**, for MegaPulse Output Resistor Network refer to **Figure 4**. The rear panel features of the MegaPulse are shown in **Figure 5** and described in **Table 2**.

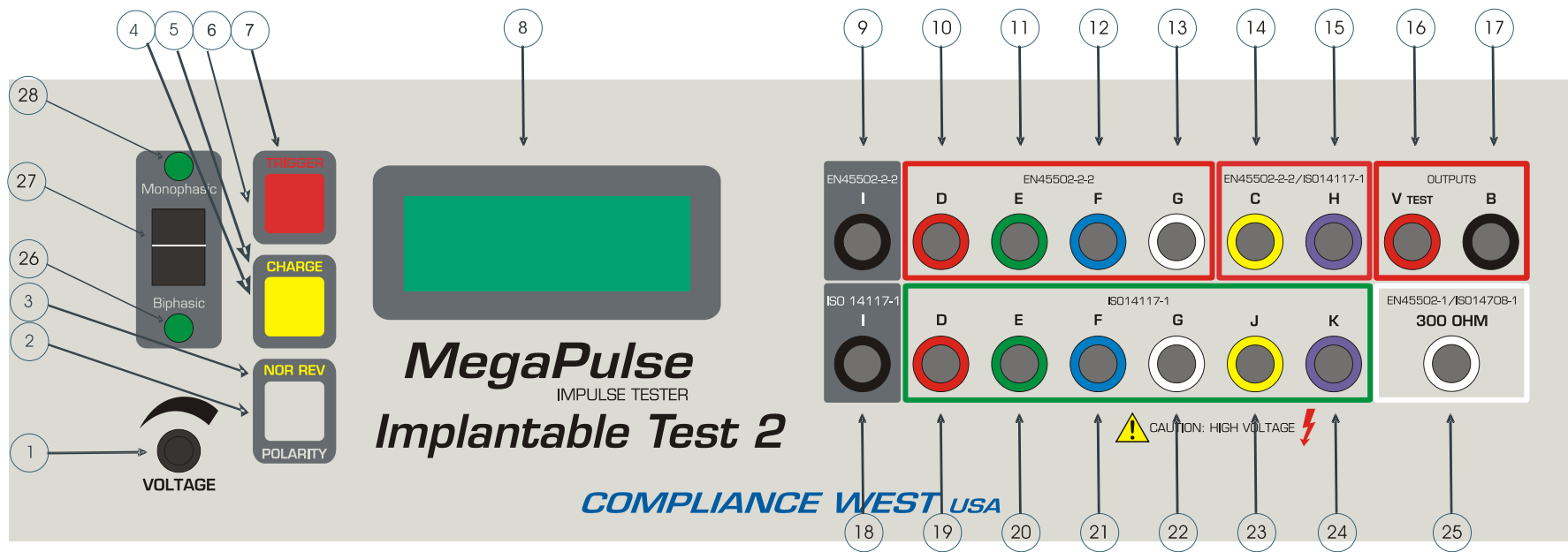

Figure 3. Controls, Indicators, Connectors – MegaPulse Implantable Test 2 Front Panel.

ITEM	NAME	FUNCTION
1	VOLTAGE Adjust Knob	Adjust the voltage set point in the tester. Turn Clockwise to increase the output voltage after the CHARGE button has been pressed. Turn the knob fully counterclockwise (lowest voltage setting) before the start of each test, and after the end of each test.
2	POLARITY switch	Toggles the output pulse polarity from Normal to Reverse, Normal for positive and Reverse for Negative, The pulse will appear on the Output jack relative to the return jack The polarity switch only operates when the CHARGE indicator is lit and the voltage on the display meter is less than 50V . The polarity is Normal when the NOR indicator is lit and, Reverse when the REV indicator is lit.
3	NOR REV indicator	Indicates the state of the Output Polarity switch. NOR indicates Normal (Positive) position. REV indicates Reverse (Negative) position.
4	CHARGE switch	Starts the charge process of the tester capacitor. The CHARGE indicator will turn off after the CHARGE switch is pressed, and the TRIGGER indicator will turn on. The charge process will stop after 2 minutes if the TRIGGER button is not pressed.
5	CHARGE indicator	This Yellow indicator is lit to show that pressing the CHARGE switch is the next logical step in a test sequence. CHARGE indicator is lit when the tester is turn ON an after pressing TRIGGER button. CHARGE indicator will go out after pressing CHARGE button. CHARGE and TRIGGER Indicators will be blinking if the Interlock Switch is open. (Only testers with Interlock Switch Option)
6	TRIGGER switch	Triggers the output impulse waveform. The impulse waveform will appear across the output leads.
7	TRIGGER indicator	This Red indicator is lit to show that the tester can be trigger. TRIGGER indicator is lit for 2 minutes after the CHARGE button is pressed. TRIGGER indicator will go out after pressing TRIGGER button. TRIGGER and CHARGE Indicators will be blinking if the Interlock Switch is open (Only testers with Interlock Switch Option) TRIGGER indicator will blink at when the Voltage. This effect will remain on until the TRIGGER switch is pressed. (Only testers with PC Interface option)
8	VOLTAGE meter	Displays the output voltage set point. The voltage reading will increase from zero to the voltage set point when the CHARGE button is pressed. Note that the Voltage meter may indicate that some residual voltage is present on the main storage capacitor, even when the tester is first turned ON. This is due to inherent charging of the internal capacitors. Pressing the TRIGGER switch will discharge the capacitors. Note that the peak amplitude of the measured output waveform is proportional to the voltage that is read on the front panel of the MegaPulse, but it can be lower, depending on the load, the higher the load the peak voltage will be higher, the MegaPulse meter is calibrated for a load of 65Ω, that is the nominal value for standard EN45502-2-2 and ISO 14117-1. The meter will start to flash at 285V to indicate that voltage is in the maximum limits. If unit includes PC Interface and the Keyboard is locked, the display will show OFF when a button is pressed.

ITEM	NAME	FUNCTION
9	EN 45502-2-2 (I) jack	Connect the black plug black cable test lead to this jack when testing for EN 45502-2-2 (0Ω).
10	EN 45502-2-2 (D) jack	Connect the red plug red cable test lead to this jack when testing for EN 45502-2-2 (800Ω).
11	EN 45502-2-2 (E) jack	Connect the green plug red cable test lead to this jack when testing for EN 45502-2-2 (400Ω).
12	EN 45502-2-2 (F) jack	Connect the blue plug red cable test lead to this jack when testing for EN 45502-2-2 (800Ω).
13	EN 45502-2-2 (G) jack	Connect the white plug red cable test lead to this jack when testing for EN 45502-2-2 (400Ω).
14	EN 45502-2-2 / ISO 14117-1 (C) jack	Connect the yellow plug red cable test lead to this jack when testing for EN 45502-2-2 and ISO 14117-1 (50Ω).
15	EN 45502-2-2 / ISO 14117-1 (H) jack	Connect the purple plug red cable with green test lead to this jack when testing for EN 45502-2-2 and ISO 14117-1 (50Ω).
16	“Vtest” Output jack	Direct output of the surge generator, measured through a 1KOhm resistor, for connection to an oscilloscope to monitor the surge generator output waveform. Connect the red plug red cable test lead to this jack.
17	“B” Output jack	Direct output of the surge generator (signal return), for connection to an oscilloscope to monitor the surge generator output waveform. Connect the black plug black cable test lead to this jack.
18	ISO 14117-1 (I) jack	Connect the black plug black cable test lead to this jack when testing for ISO 14117-1 (50Ω).
19	ISO 14117-1 (D) jack	Connect the red plug green cable test lead to this jack when testing for ISO 14117-1 (600Ω).
20	ISO 14117-1 (E) jack	Connect the green plug green cable test lead to this jack when testing for ISO 14117-1 (300Ω).
21	ISO 14117-1 (F) jack	Connect the blue plug green cable test lead to this jack when testing for ISO 14117-1 (600Ω).
22	ISO 14117-1 (G) jack	Connect the white plug green cable test lead to this jack when testing for ISO 14117-1 (300Ω).
23	ISO 14117-1 (J) jack	Connect the yellow plug green cable test lead to this jack when testing for ISO 14117-1 (600Ω).
24	ISO 14117-1 (K) jack	Connect the purple plug green cable test lead to this jack when testing for ISO 14117-1 (300Ω).
25	EN 45502-1 / ISO 14708-1 300Ω jack	Connect the white plug white cable test lead to this jack when testing for EN 45502-1 and ISO 14708-1 (300Ω).
26	Biphasic indicator	Indicates the type of waveform Biphasic .
27	Waveform Select switch	Used to select the type of waveform, Biphasic or Monophasic .
28	Monophasic indicator	Indicates the type of waveform Monophasic .

Table 1. Controls, Indicators, Connectors – MegaPulse Implantable Test 2 Front Panel

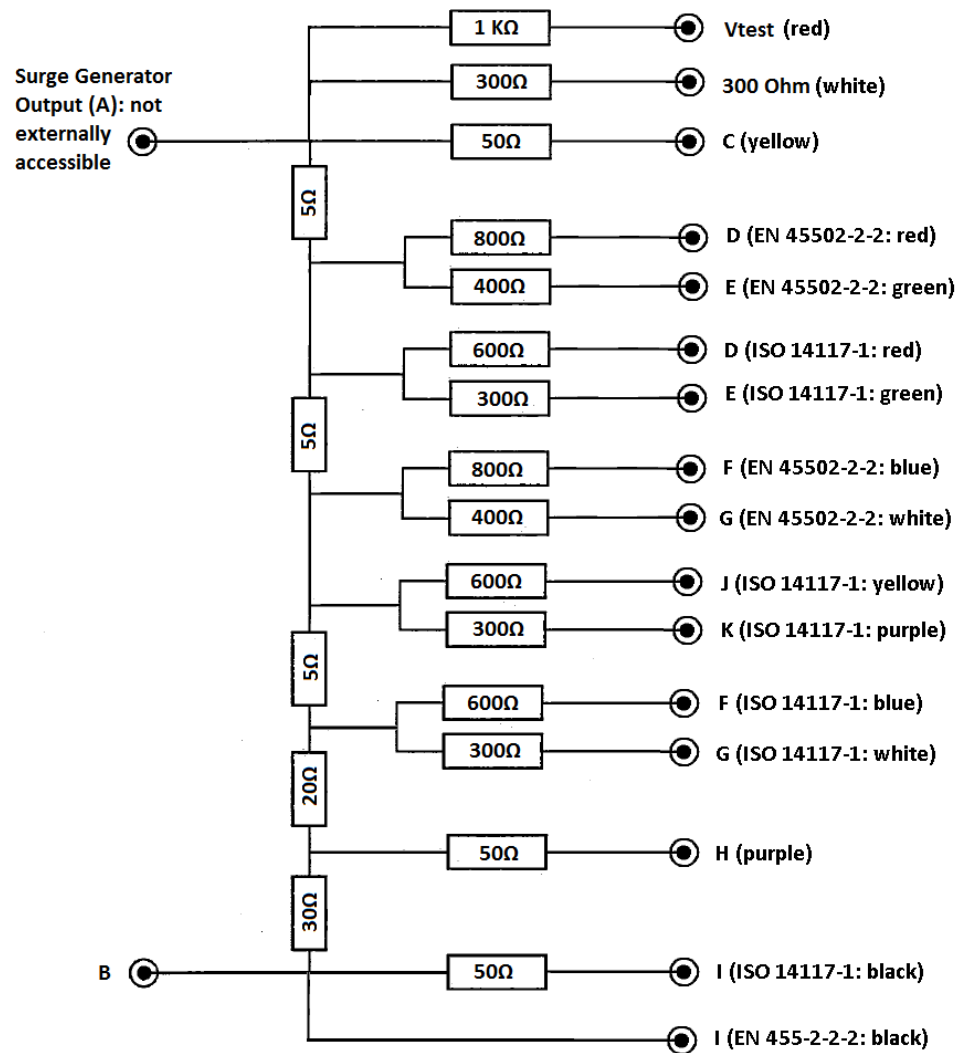

Figure 4. Output Resistor Network for the Megapulse Implantable Test 2.

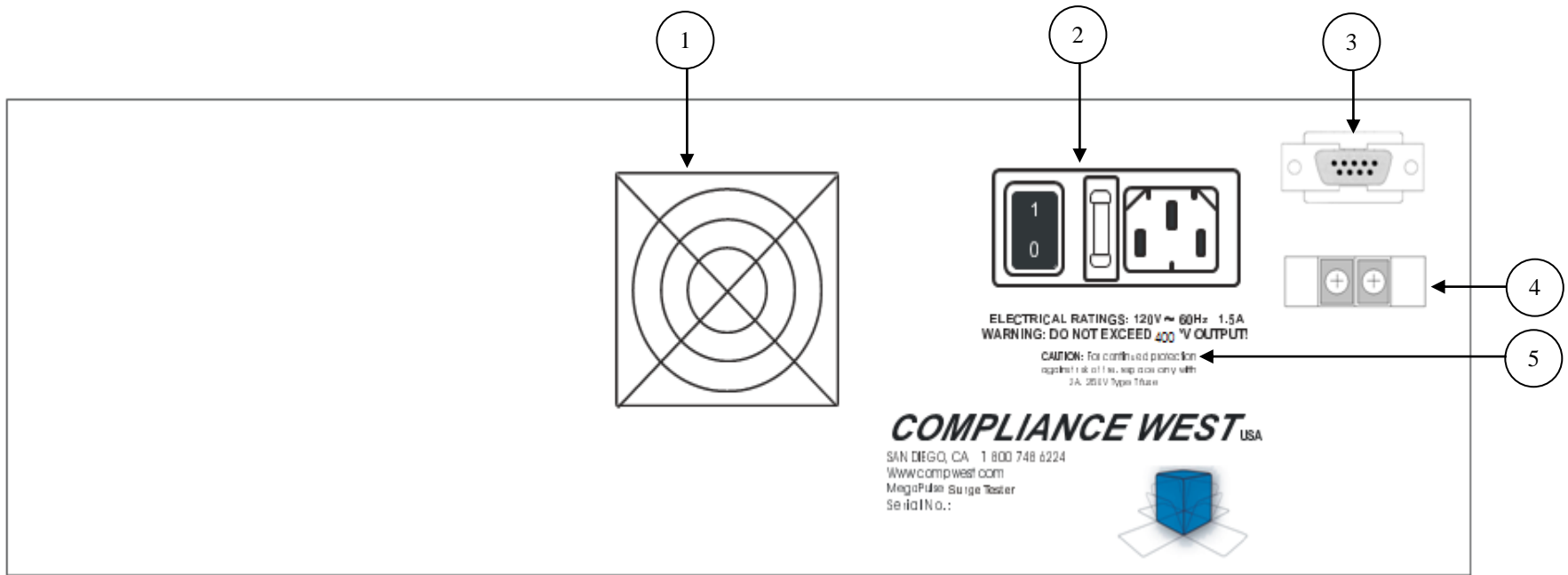

Figure 5. Controls, Indicators, Connectors – MegaPulse Implantable Test 2 Rear Panel.

ITEM NO.	NAME	FUNCTION
1	Fan	Design to cool down the tester.
2	Appliance Inlet / Fuse holder / Power Switch	Use supplied cordset to connect the MegaPulse Implantable Test 2 tester to an appropriate source of supply. Fuse holder provides access for Fuse replacement, and the Power Switch is used to turn the tester ON and OFF.
3	RS-232 Interface (Optional)	Allow the communication between the tester and computer interface; a RS-232 to USB is available.
4	Interlock Switch (Optional)	Emergency Stop Close: Enables the tester buttons for operation. Open: Stops any process in the tester and disables the buttons. The TRIGGER and CHARGE Indicators will be blinking
5	Fuse replacement warning / Rating of power supply	Specifies replacement fuse and required supply voltage.

Table 2. Control, Indicators, Connectors – MegaPulse Implantable Test 2 Rear Panel.

Initial Checkout Procedure

The following procedure will verify that the MegaPulse Implantable Test 2 tester is working correctly. We recommend that this procedure be conducted periodically to ensure proper operation of the tester. The following items are needed to conduct this procedure: A measuring instrument to monitor the output waveform. Always ensure that the measuring instrument (usually an oscilloscope with a 10X probe) is rated for the voltage involved, and that the frequency response of the instrument and probe are capable of measuring the output waveform of the MegaPulse Implantable Test 2 tester. A measuring instrument or probe with a low frequency response will result in erroneous readings that could be mis-read.

CAUTION

High voltage generated by the MegaPulse tester is exposed during this test. A risk of shock exists. Exercise care when using the MegaPulse tester.

1. Connect the tester to a proper source of supply using the included 18 AWG power supply cord. Make sure that the front panel **VOLTAGE** adjust knob is turned fully counterclockwise.
2. Plug the red test lead to the **Vtest** Output jack and the black test lead to the **B** jack on the front panel.
3. Connect the ends of the test leads to an appropriate measuring instrument (typically an oscilloscope with a 10X probe). See **Figure 6** as an example.
4. Turn the Tester on. Toggle the **POLARITY** switch if necessary so that the **NOR** indicator is lit. Push the **Waveform Type** switch until to select a **Monophasic** waveform.
5. Note that the Voltage meter may indicate that some residual voltage is present on the main storage capacitor, even when the tester is first turned ON. This is due to inherent charging of the internal capacitors. Pressing the **TRIGGER** switch will discharge the capacitors (be sure not to touch the outputs leads when pressing the trigger switch).
6. Push the yellow **CHARGE** button. Verify the red **TRIGGER** indicator is now lit.
7. Adjust the **VOLTAGE** knob so that the front panel LED display is reading 270V. Push the red **TRIGGER** button, and view the resulting impulse waveform on the measuring instrument.
8. Repeat steps 5 through 7, except this time toggle the **POLARITY** switch so that the **REV** indicator is lit. Note that the impulse waveform will now be a negative pulse, so it will probably be necessary to make adjustments to the measuring instrument to get a proper reading.
9. Repeat steps 5 through 7, except this time toggle the **Waveform Type** switch so that the **Biphasic** indicator is lit. Note that the impulse waveform will now be a negative pulse, so it will probably be necessary to make adjustments to the measuring instrument to get a proper reading.
10. Adjust the **VOLTAGE** knob fully counterclockwise, to the minimum position. Turn the rear-panel power switch OFF.

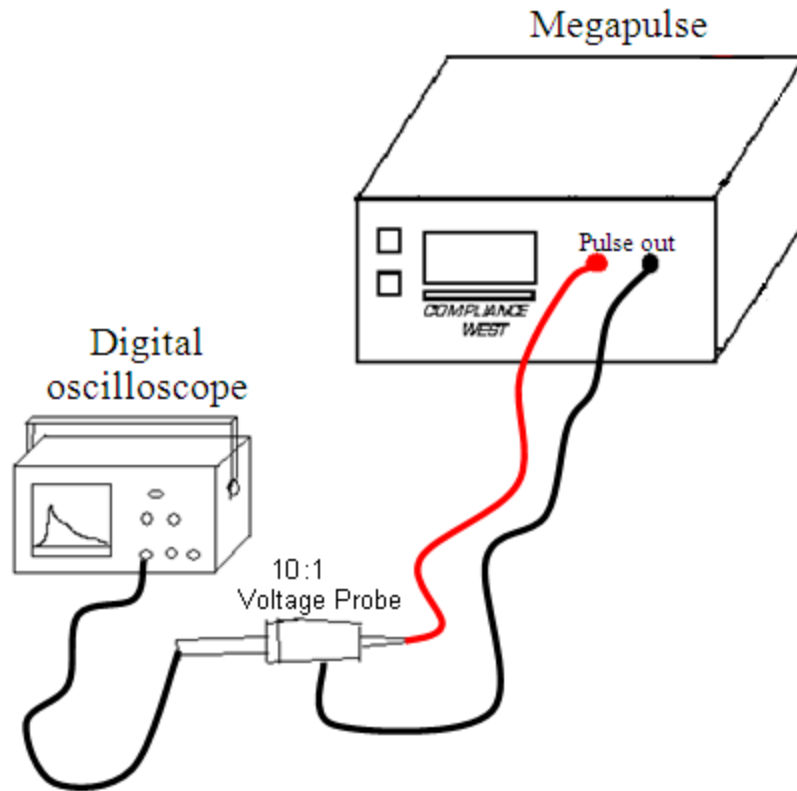

Figure 6. Waveform Measurement Setup.

Testing

This section describes how the MegaPulse Implantable Test 2 tester is used to conduct a test. The test can be stopped immediately at any time by turning OFF the rear-panel power switch.

1. Connect the tester to a proper source of supply using the included 18 AWG power supply cord. Make sure that the front panel **VOLTAGE** adjust knob is turned fully counterclockwise.
2. Connect the corresponding Outputs to the device under test.
3. Turn the Tester on. Toggle the **POLARITY** switch as needed so that the **NOR** or **REV** indicator is lit.
4. Connect the **Vtest** and **B** Output jacks to an appropriate measuring instrument (typically an oscilloscope with a 10X voltage probe). See **Figure 6** as an example.
6. Connect the rest of the test leads to the device under test.
5. Note that the Voltage meter may indicate that some residual voltage is present on the main storage capacitor, even when the tester is first turned ON. This is due to inherent charging of the internal capacitors. Pressing the **TRIGGER** switch will discharge the capacitors (be sure not to touch the output and return leads when pressing the trigger switch).
6. Push the yellow **CHARGE** button. Verify the red **TRIGGER** indicator is now lit.
7. Adjust the **VOLTAGE** knob so that the front panel LED display is reading 270V. Push the red **TRIGGER** button, when the desired voltage is displayed on the front panel meter.

Section 4

Technical Assistance

Technical Assistance from Compliance West USA is available:

Phone: (800) 748-6224

Hours: 8:30 AM - 4:30 PM Pacific Time.

Also available on our web site at: **www.compwest.com**

Contact:

Compliance West USA
650 Gateway Center Way Suite D
San Diego, CA 92102 USA.

Phone: (619) 878-9696

FAX: (619) 794-0404

Section 5

Maintenance and Calibration

WARNING

MAINTENANCE AND CALIBRATION INSTRUCTIONS ARE FOR QUALIFIED PERSONNEL ONLY. TO AVOID ELECTRIC SHOCK, DO NOT PERFORM ANY SERVICING OTHER THAN THE CONTAINED IN THE OPERATING INSTRUCTIONS.

Introduction

This section of the manual contains maintenance information for the MegaPulse Implantable Test 2 impulse tester. A 1-year calibration cycle is recommended to maintain the specifications of the factory. The test equipment required for the performance test is a digital oscilloscope, high voltage oscilloscope probe, digital meter and a high voltage probe.

Service Information

The MegaPulse tester is warranted to the original purchaser for a period of 1 year. This warranty does not cover problems due to misuse or neglect. Malfunctions which occur within the limits of the warranty will be corrected at no charge. Mail the instrument post paid to the manufacturer. Dated proof of purchase is required for all in-warranty repairs. The manufacturer is also available for calibration and / or repair of instruments that are beyond their warranty period. Contact the manufacturer for a cost quotation. Ship the instrument and your remittance according to the instructions given by the manufacturer.

General Maintenance

To avoid contaminating the PWB with oil from your fingers, handle it by the edges or wear gloves. If the PWB becomes contaminated, refer to the cleaning procedures given later in this section.

WARNING

Dangerous voltages exist when energized. Exercise extreme care when working on an energized circuit.

Cleaning

Clean the front panel and case with a mild solution of detergent and a damp sponge. Clean dust from the PWB with clean, dry, low pressure (<20 psi)

CAUTION

Do not use aromatic hydrocarbons or chlorinated solvents for cleaning. These solutions will react with the plastic materials used in the instrument.

Calibration Information

The Calibration Procedure should be performed annually and any time the instrument has been repaired. The calibration procedure should be performed at an ambient temperature of 23°C ±5°C (73.4°F ±9°F). The procedure consists on waveform tolerance verification and calibrating the meter reading to agree with the voltage amplitude with a 65Ω load. The Calibration procedure must be performed by qualified personnel, for more information contact Compliance West USA.

Voltage Stop Disable / Keyboard Enable by Keyboard.

If the MegaPulse Implantable Test 2 tester includes TestMinder option and has the Voltage Stop by the PC command activated, it is possible to disable it using the next keyboard sequence:

Note: Disabling Voltage Stop enables the keyboard.

Turn OFF the MegaPulse P tester.

Hold in the **TRIGGER** and **NOR-REV** buttons.

Turn ON the MegaPulse P tester.

Wait until the display shows **rESE**.

Release the **TRIGGER** and **NOR-REV** buttons.